

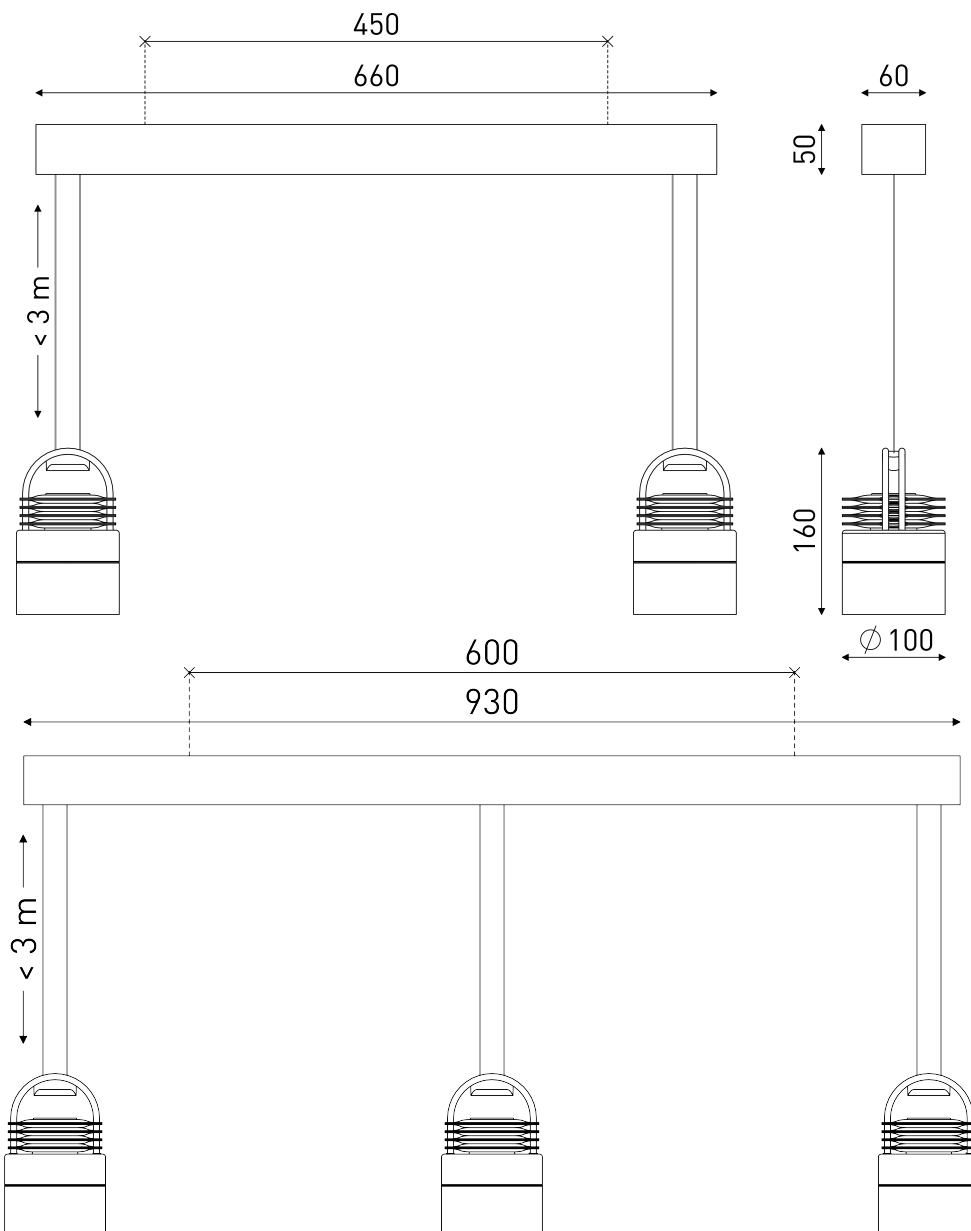

Sammode
Studio

AIRMOD

Duo & Trio



Installation

Installation / Installation

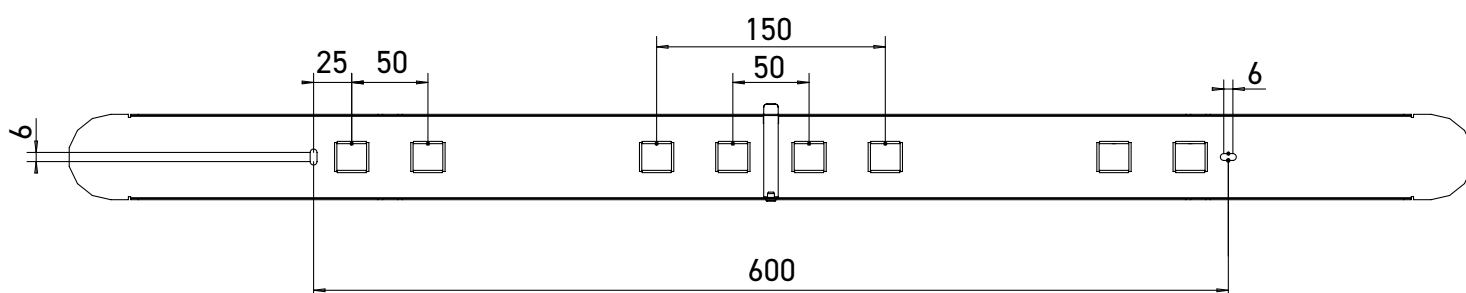
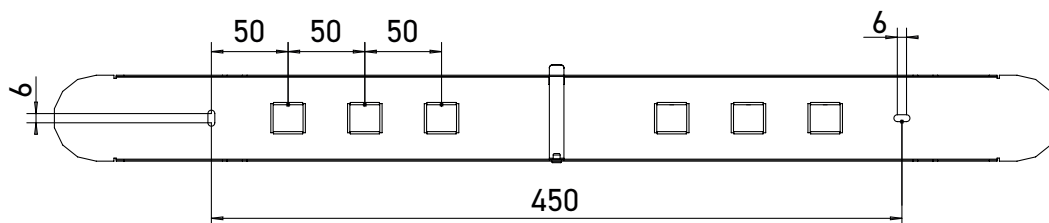

1.

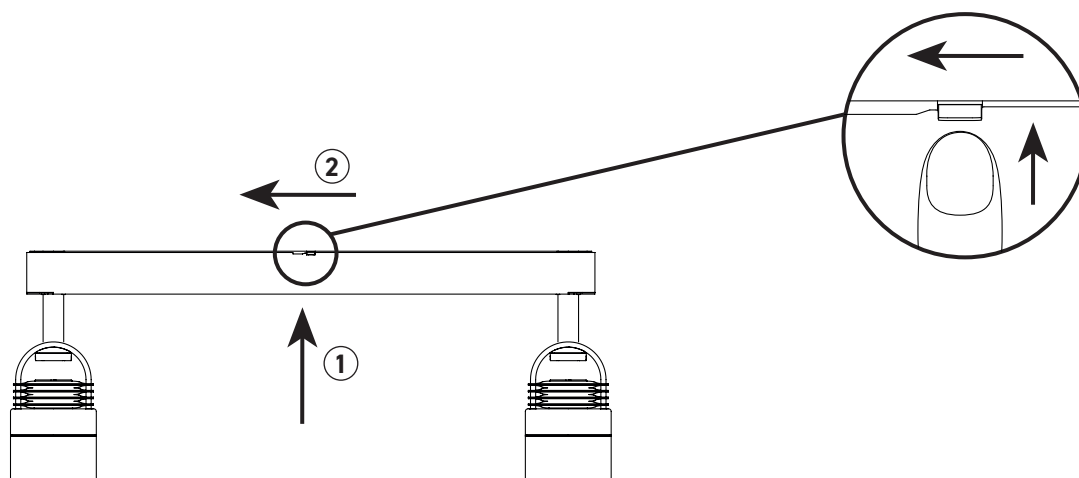

2.

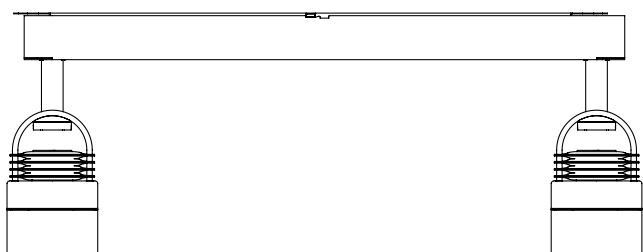

3.

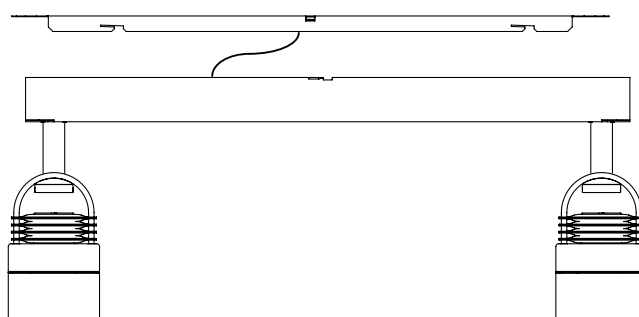

4.

ON-OFF / RB

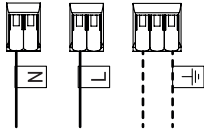

DALI / RD

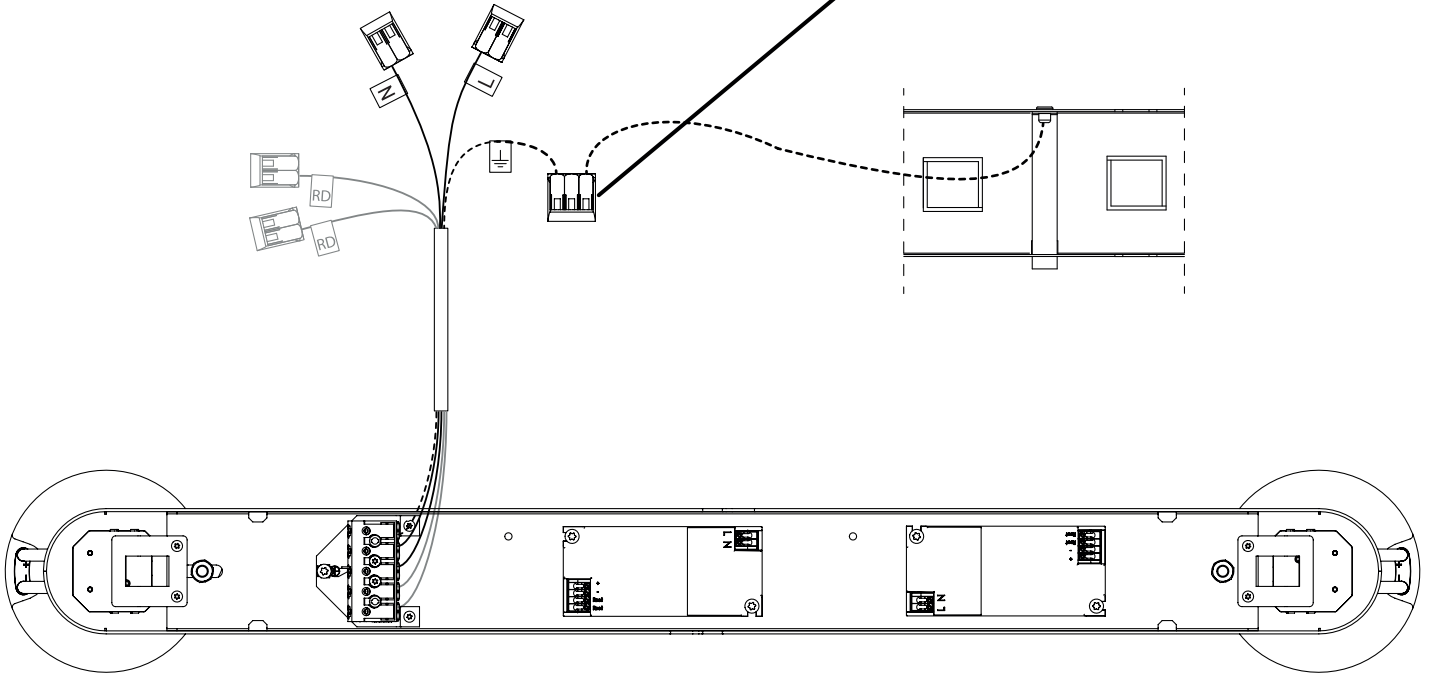
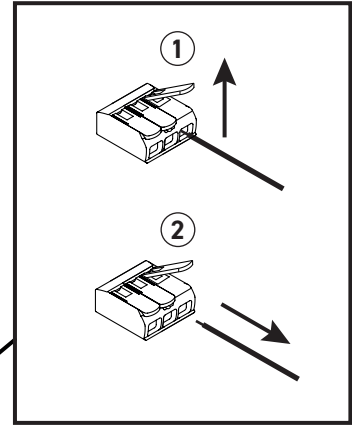
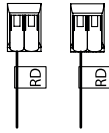

5.

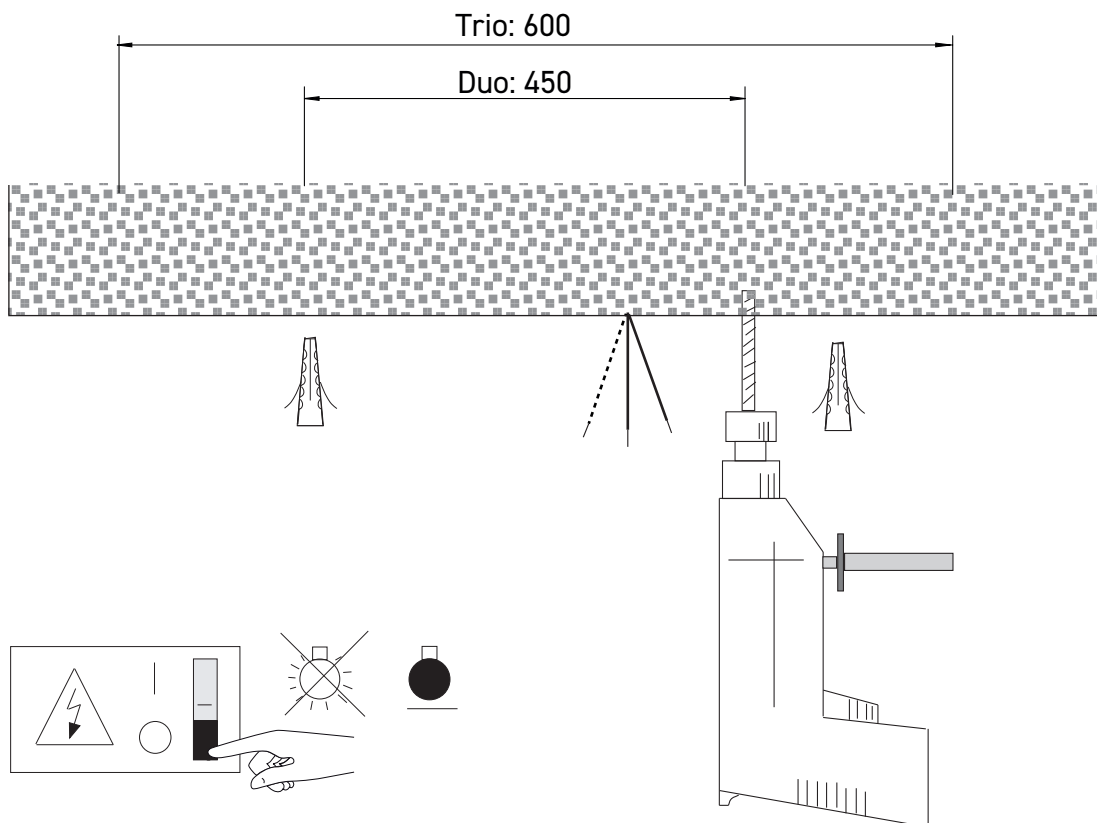

6.

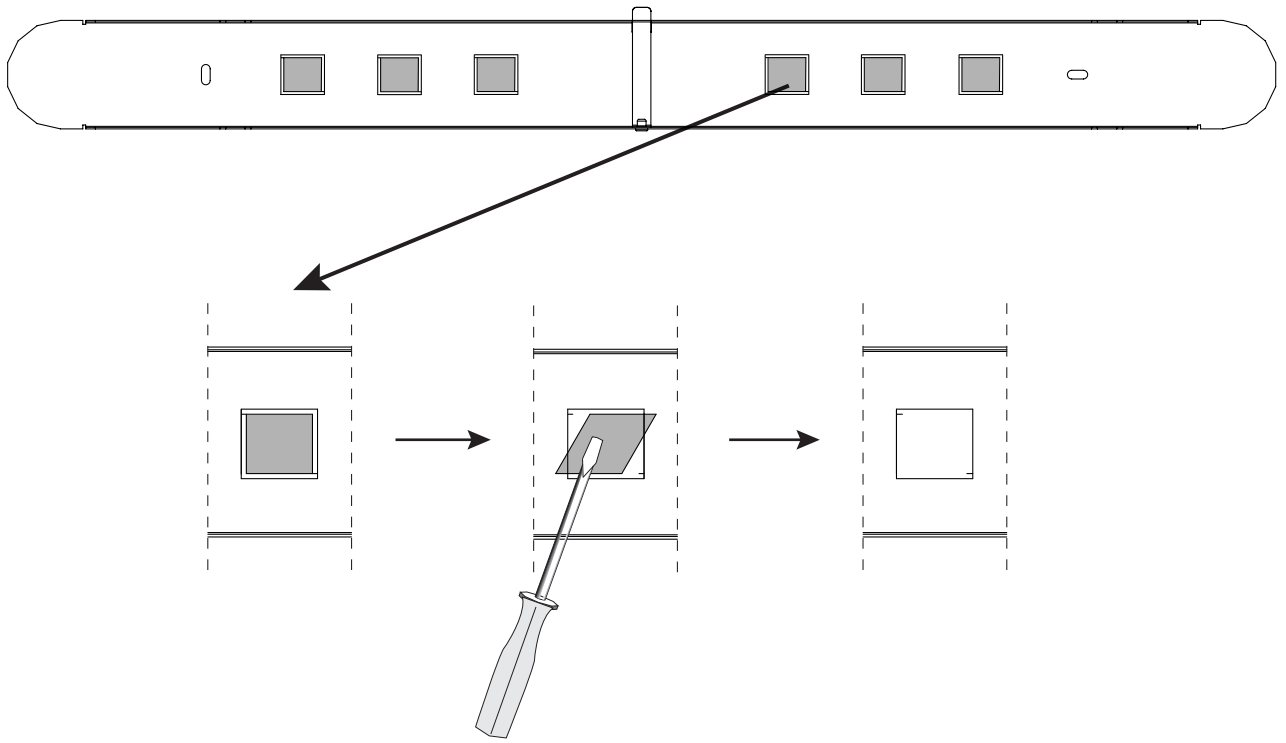

7.

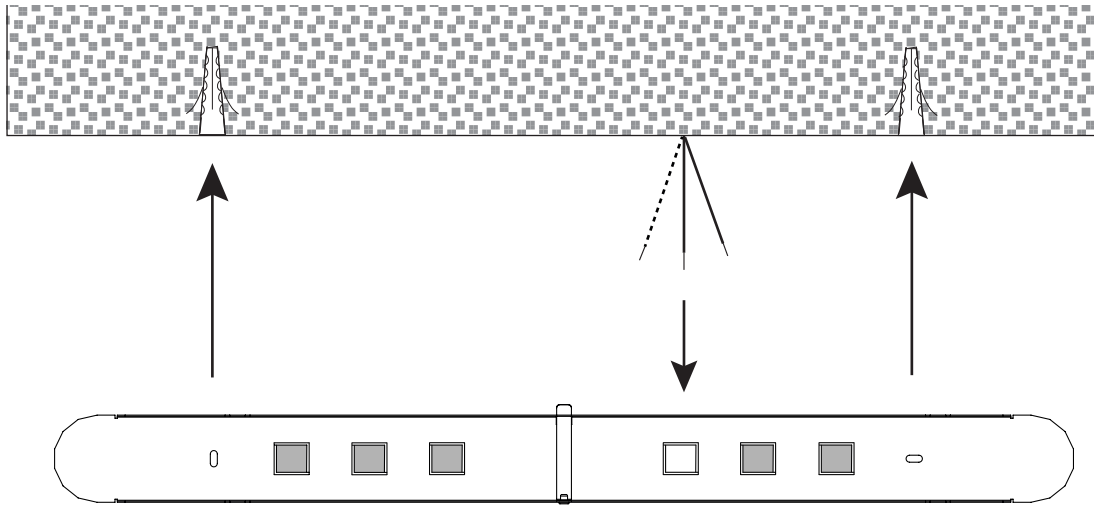

8.

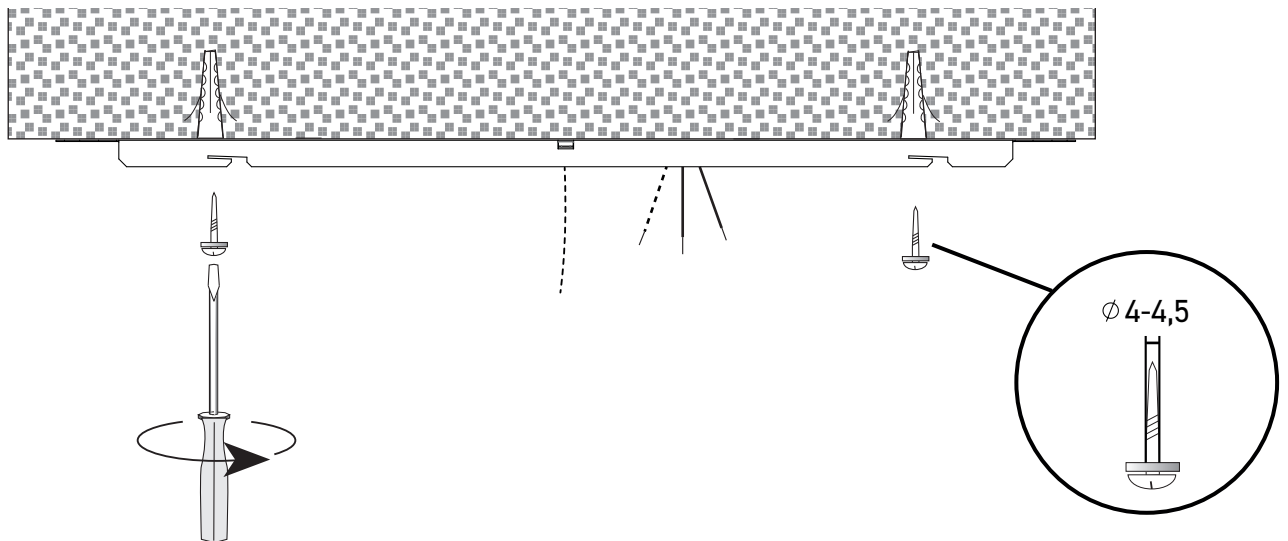

9.

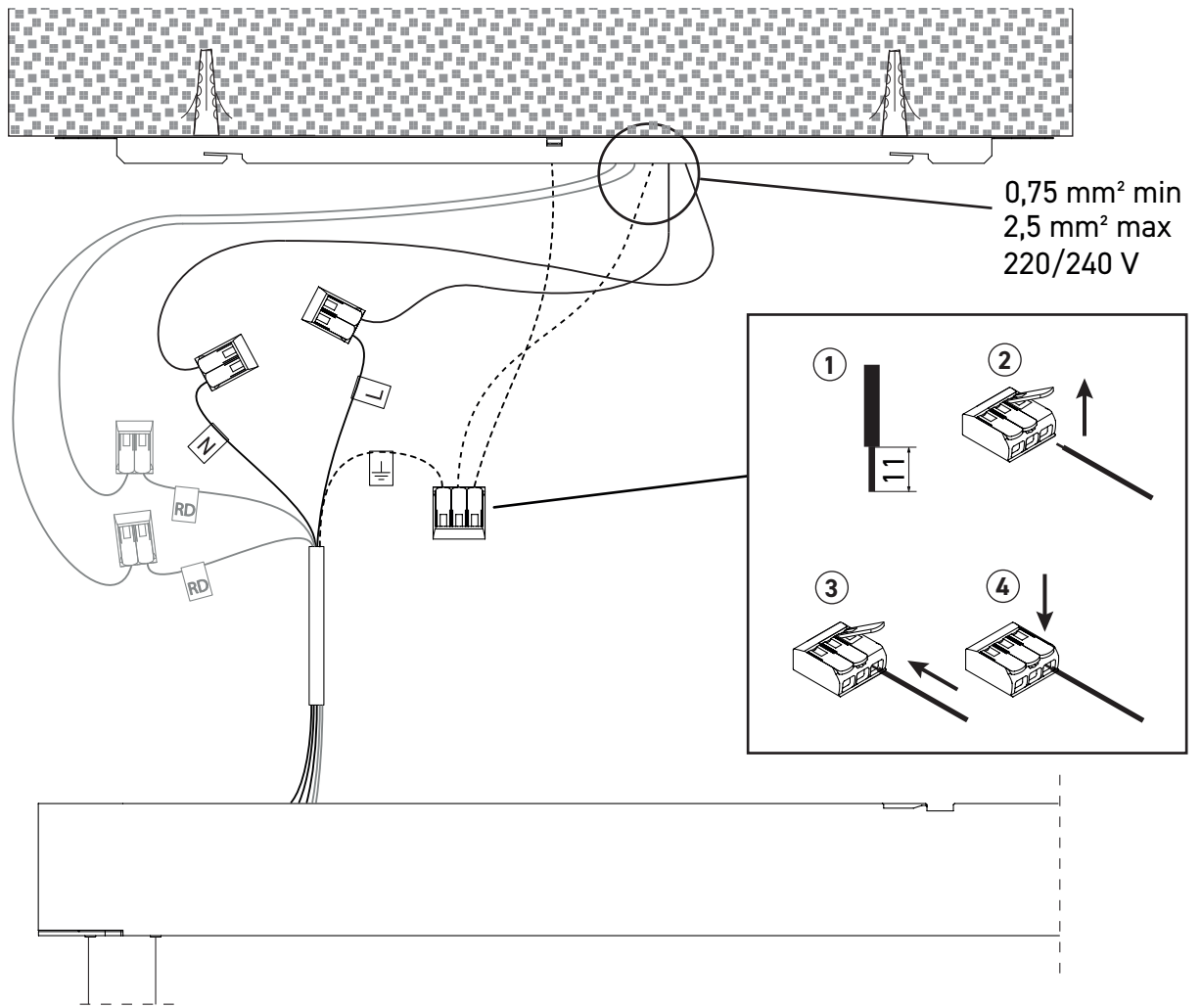

10.

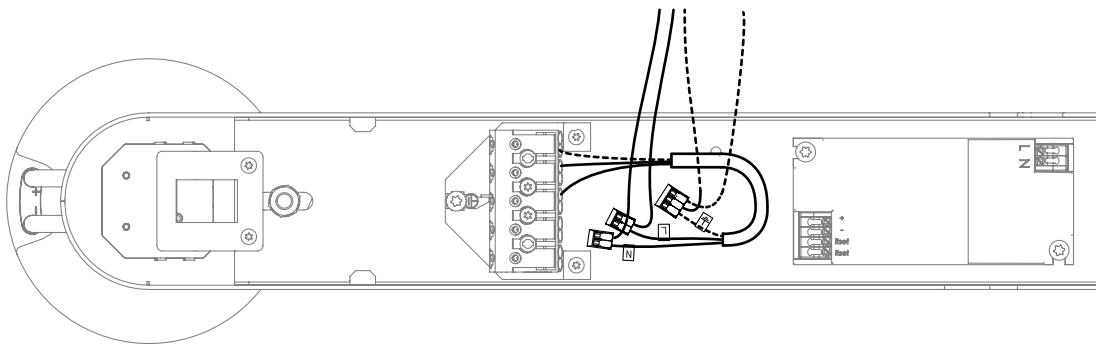

11.

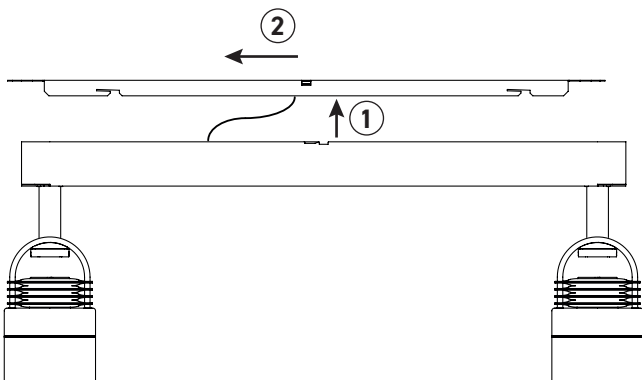

12.

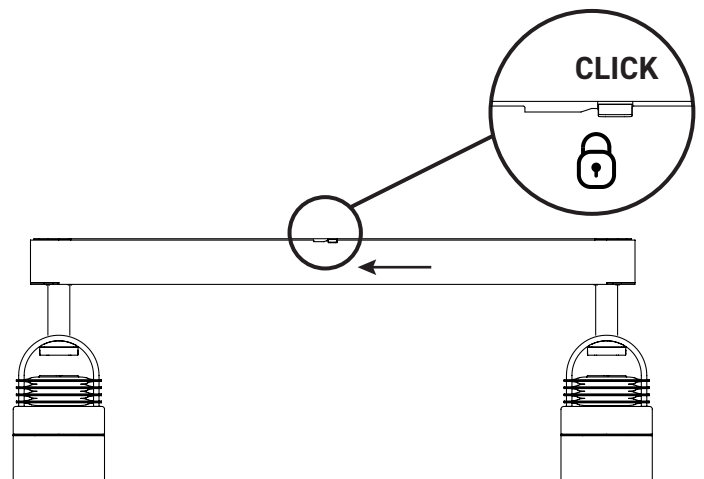

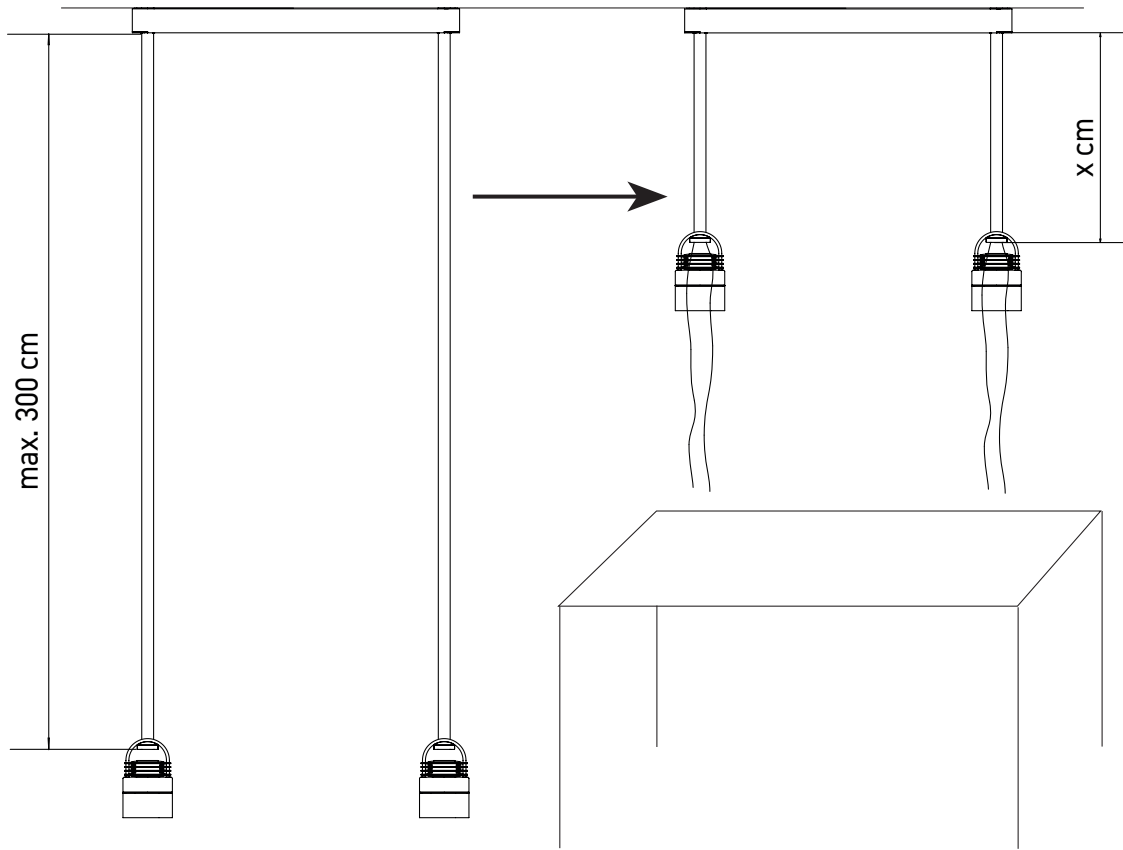

13.

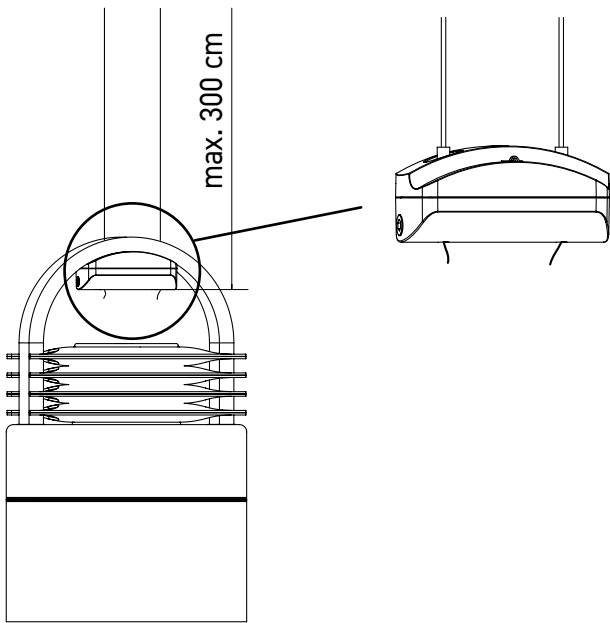

14.

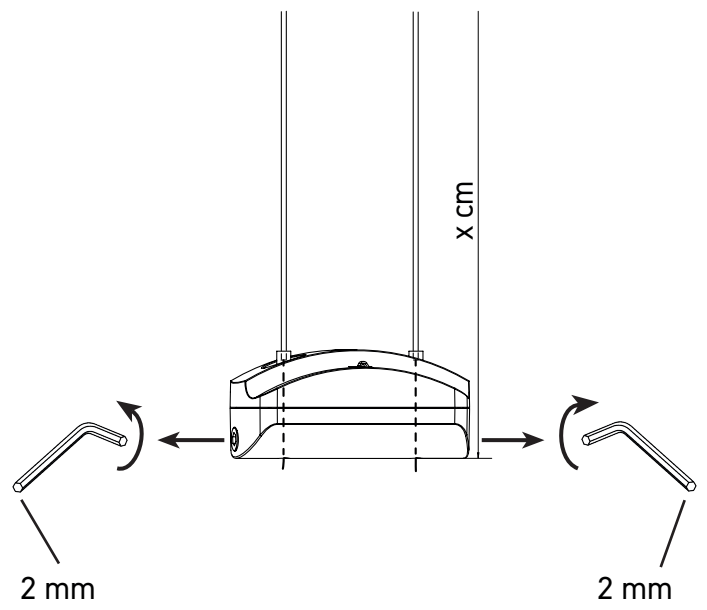

15.

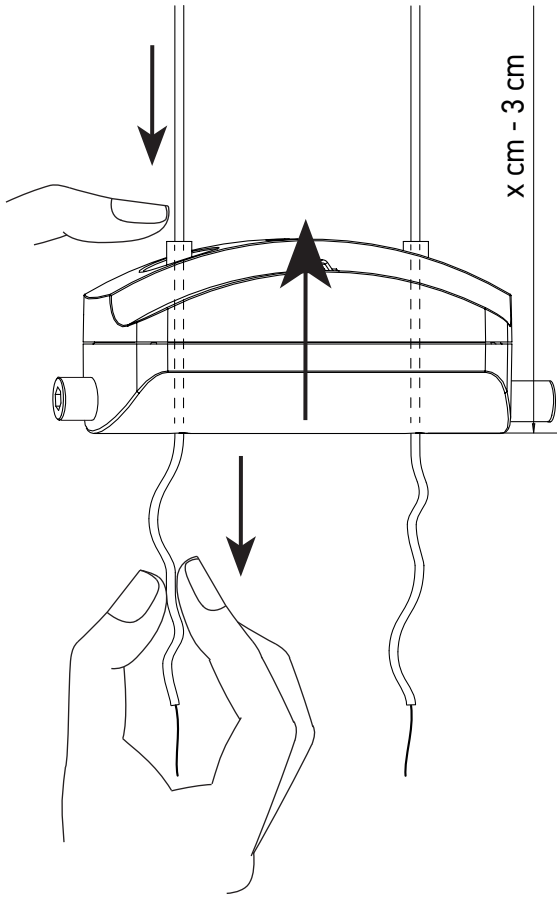

16.

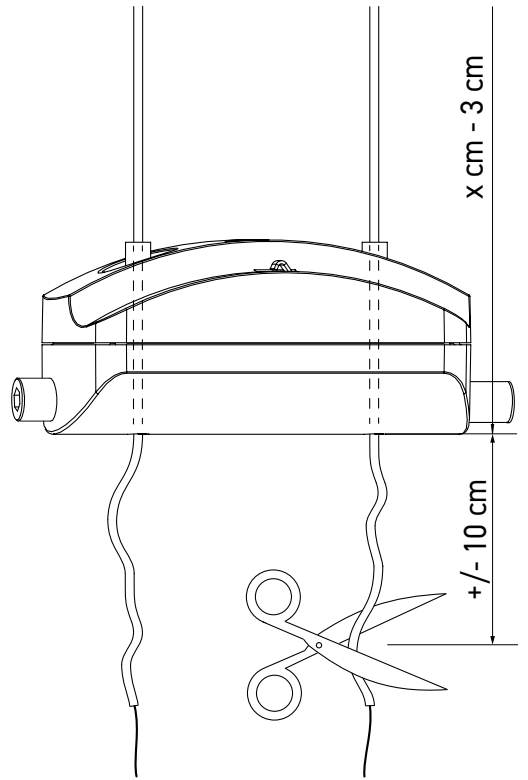

17.

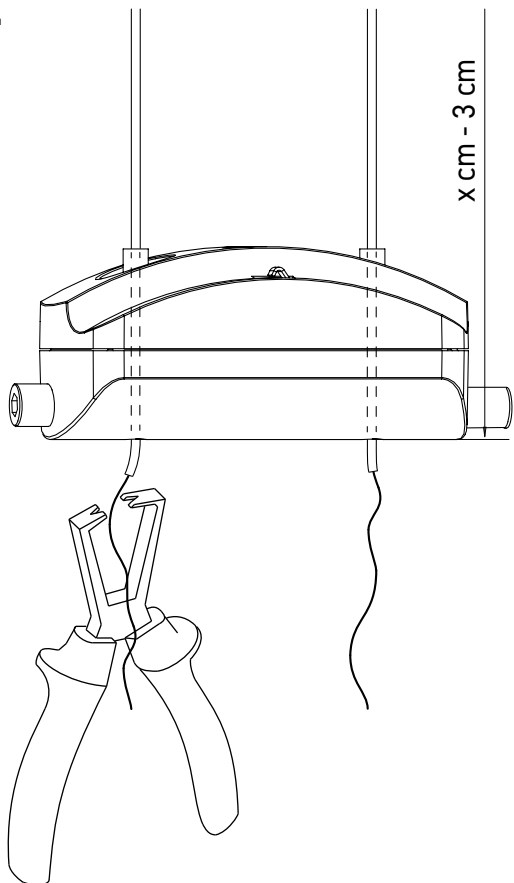

18.

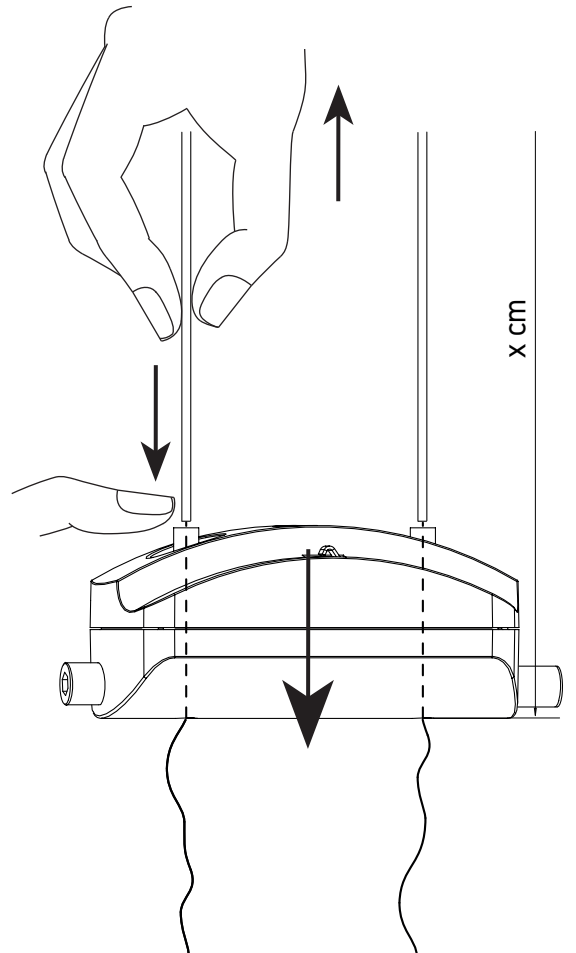

19.

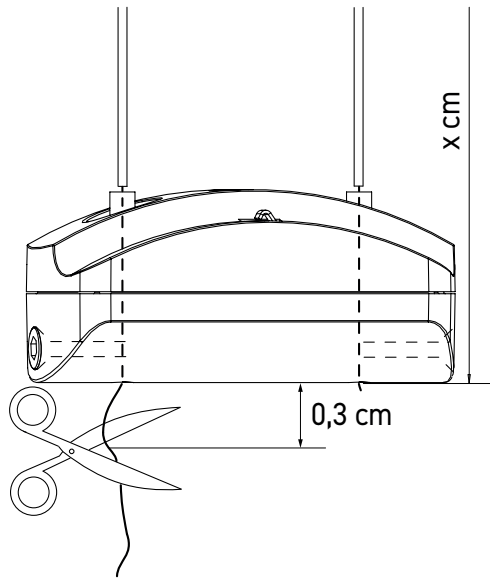

20.

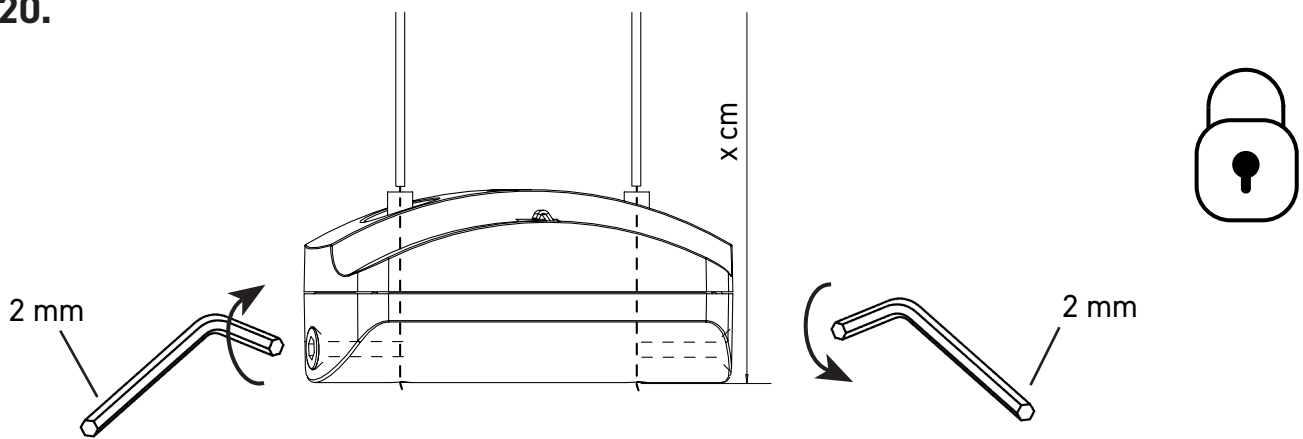

Casambi User Guide



FR -Attention, Risque de choc électrique. Mettre hors tension avant intervention.
GB -Caution, risk of electric shock. Disconnect before servicing.
D -Vorsicht, Stromschlaggefahr. Vor Wartungsarbeiten abklemmen

FR-La source lumineuse contenue dans ce luminaire ne doit être remplacée que par le fabricant ou son agent de maintenance ou une personne de qualification équivalente.
GB- The light source contained in this luminaire shall only be replaced by the manufacturer or his service agent or a similar qualified person.
D- Die Lichtquelle dieser Leuchte darf nur vom Hersteller oder ihm Servicetechniker oder einer vergleichbar qualifizierten Person ersetzt werden.

FR-Le dessus de la partie éclairante du luminaire peut être chaude ; ajuster le spot après son refroidissement ou utiliser des gants thermiques.
GB-The top of lighting part can be perceived as hot; adjust it after the luminaire is cooled down or use heat insulating gloves.
D-Die Oberseite des Beleuchtungsteils kann als heiß wahrgenommen werden. Stellen Sie es nach dem Abkühlen der Leuchte ein oder verwenden Sie wärmeisolierende Handschuhe.

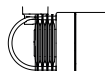

nettoyer une fois le luminaire refroidi. Nettoyage uniquement avec un chiffon doux.
cleaning after the luminaire is cooled down. Cleaning only with soft cloth.
Reinigen Sie die Leuchte nach dem Abkühlen . Reinigung nur mit einem weichen Tuch.



Art. No. 123 970
12/2020